

**Model 8502M3  
Model 8502M7  
Model 8502M9**



**IR-EYE™  
Directional Miniature  
Passive Infrared Thermal Telescopes**

**with:  
Analog Output(s) to mate with  
Contractor-Developed Signal Processing  
or Legacy Systems**



**Please note: These telescopes do not provide either relay or TTL outputs. They are made available for special signal processing systems. For units that do provide relay and TTL outputs, contact Eltec Instruments, Inc.**

***THIS PAGE LEFT INTENTIONALLY BLANK***

# **SECTION 1**

## **INTRODUCTION**

- 1.1 RANGE AND PERFORMANCE
- 1.2 BASICS OF PASSIVE INFRARED (PIR) DETECTION
- 1.3 DESCRIPTION
- 1.4 FUNCTION
- 1.5 FIELD-OF-VIEW
- 1.6 DIRECTIONAL CONSIDERATIONS
- 1.7 DETECTABILITY CONSIDERATIONS
- 1.8 ENVIRONMENTAL CONSIDERATIONS
- 1.9 INSTALLATION CONSIDERATIONS
- 1.10 POTENTIAL FALSE ALARM SOURCES

# **SECTION 2**

## **INSTALLATION AND OPERATION**

- 2.1 INTRODUCTION AND PRECAUTIONS
- 2.2 UNPACKING
- 2.3 POWER REQUIREMENTS
- 2.4 CONNECTION TO EXTERNAL EQUIPMENT
- 2.5 TAMPER SENSE
- 2.6 AMPLIFICATION REQUIREMENTS
- 2.7 MECHANICAL OUTLINE
- 2.8 MOUNTING
- 2.9 MOUNTING AND ACCESSORIES
- 2.10 OPERATION
- 2.11 ALIGNMENT
- 2.12 WALK TESTING
- 2.13 WALK TESTING FIELD-OF-VIEW
- 2.14 MAINTENANCE
- 2.15 SPECIFICATIONS
- 2.16 ACCESSORIES

## **SECTION 1 - - INTRODUCTION**

### **1.1 RANGE AND PERFORMANCE**

The range of these telescopes is nominally 150 - 200 feet (with appropriate customer supplied electronics) for personnel and farther for vehicles. HOWEVER, range is dependent on the thermal contrast between the target and the background. You will find that this varies throughout the day, with weather conditions, and even with the clothing of the target. If your application involves detecting someone crossing through a field of grass, you will find that the undulation of the grass on a windy day will appear on the analog output signals. Thus the system is limited by the thermal contrast of the target against the background as well as thermal background noise.

For longer range (~500 ft), Eltec suggests the Model 860M1, 860M5 or 860M6. The Model 860M5 is a long range version of the Model 8502M3 and the Model 860M6 is a long range version of the Model 8502M7. The Model 8502M9 is an extra ruggedized version of the Model 8502M3 for application in deployment scenarios where the device may be subjected to high shock and/or vibration levels during transport. The short range and long range versions are pin for pin compatible and use the same connector. The short and long range versions differ with regard to directionality (refer to the Directional Considerations (Section 1.6) for the appropriate Model).

Performance will greatly depend on the amplification you use with the telescope's analog output including your bandpass filtering. Many feel that human motion is sufficiently detected through the frequency range of 0.3 to 3 Hz. Yet, the conditions of your application may require a broadening of that range - - with a consequent increase in noise. Eltec recommends that you AC-couple the telescope's analog output. The maximum current draw is 25 microamps.

### **1.2 BASICS OF PASSIVE INFRARED (PIR) DETECTION**

Each person, object or animal emits infrared energy as a function of its surface temperature and size. For temperatures around ambient the maximum of the radiated energy is in the region of 10 microns (20 times the wavelength of visible light). Thermal changes, relative to the background, within the telescope's field of view as produced by a moving target generate a signal which will trigger an alarm.

PIR detection has become the most widely used approach for indoor intrusion detection and Eltec provides a proven high reliability sensor for outdoor applications.

PIR detection does not require an emitter, but makes use of radiation which is already there - 100% natural and harmless. The fact that no radiation is emitted also means that:

- A sensor unit cannot be detected by any technical means. Like the human eye, it is completely passive in operation.
- No license is required as for microwaves.
- No eye protection required as with many active IR devices.
- Neighboring units will not interfere with each other.
- Directional information can be obtained utilizing an internal two channel detector and appropriate external electronic circuit.

### 1.3 DESCRIPTION

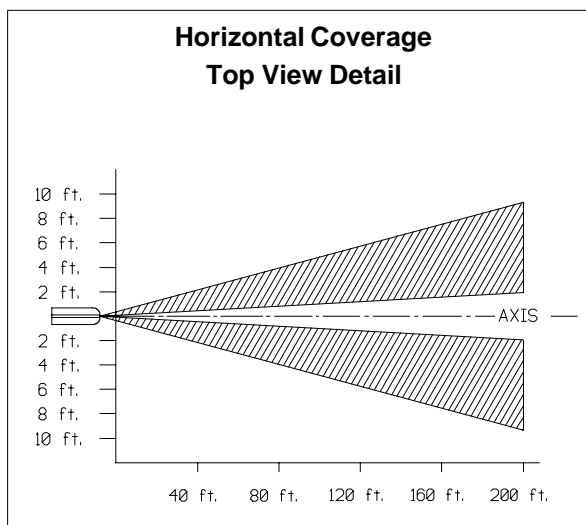
These telescopes are specifically designed for use as a component in integrated security/surveillance systems for short range detection of people and vehicles. Eltec's passive infrared thermal telescopes have been deployed worldwide for over two decades in security systems for industrial, governmental and military installations. The rugged, watertight, hermetically sealed construction of these telescopes make them ideal for outdoor applications. The miniature size is advantageous for indoor use as well as covert applications. The telescope's use of state-of-the-art detector technology and precision optics, coupled with customer provided signal processing optimizes the discrimination of moving targets from other events. This technology is an exciting alternative to microwave or active infrared links and is also ideal in critical applications where dual technologies are desired. The simple installation process, and the variety of options available, make these telescopes well suited for a number of applications, some of which include detection of personnel, vehicles, boats, airplanes, fires, explosions, etc. The telescopes can be used in both fixed and temporary installations to monitor events at moderate distances.

### 1.4 FUNCTION

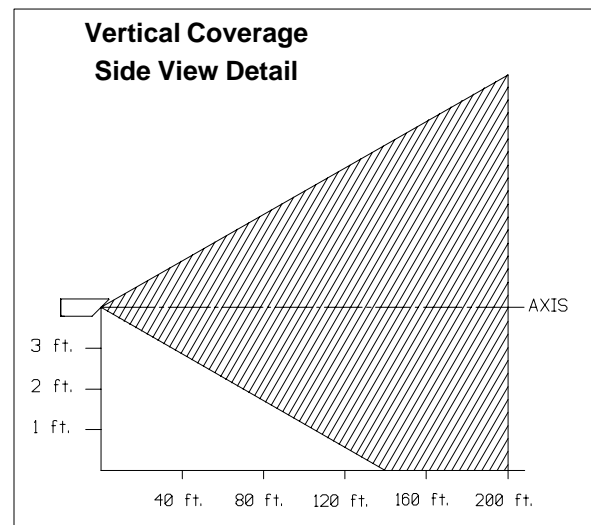
A person or vehicle will always have a temperature contrast in respect to the background, producing a change of radiation within the field of view when passing through it. This temperature contrast can be as little as 1°C or less (either positive or negative) for a person at the nominal distance of 195ft to trigger the alarm. A precision lens focuses the radiation onto a twin channel pyroelectric detector which will produce a defined signal from a moving target. Two stage optical filtering restricts the radiation to the "atmospheric window" (8 - 14 microns) where the effects of the normal constituents of the atmosphere (particularly humidity) least affect the transmission of infrared radiation. This double optical filtering minimizes unwanted radiation from sunlight or headlights which otherwise may produce false alarms.

### 1.5 FIELD-OF-VIEW

Please note: This manual discusses installation and operation of the Model 8502M3, 8502M7 and 8502M9 telescopes. The field of view is the same for all models. The difference between the models



**Figure 1.1**

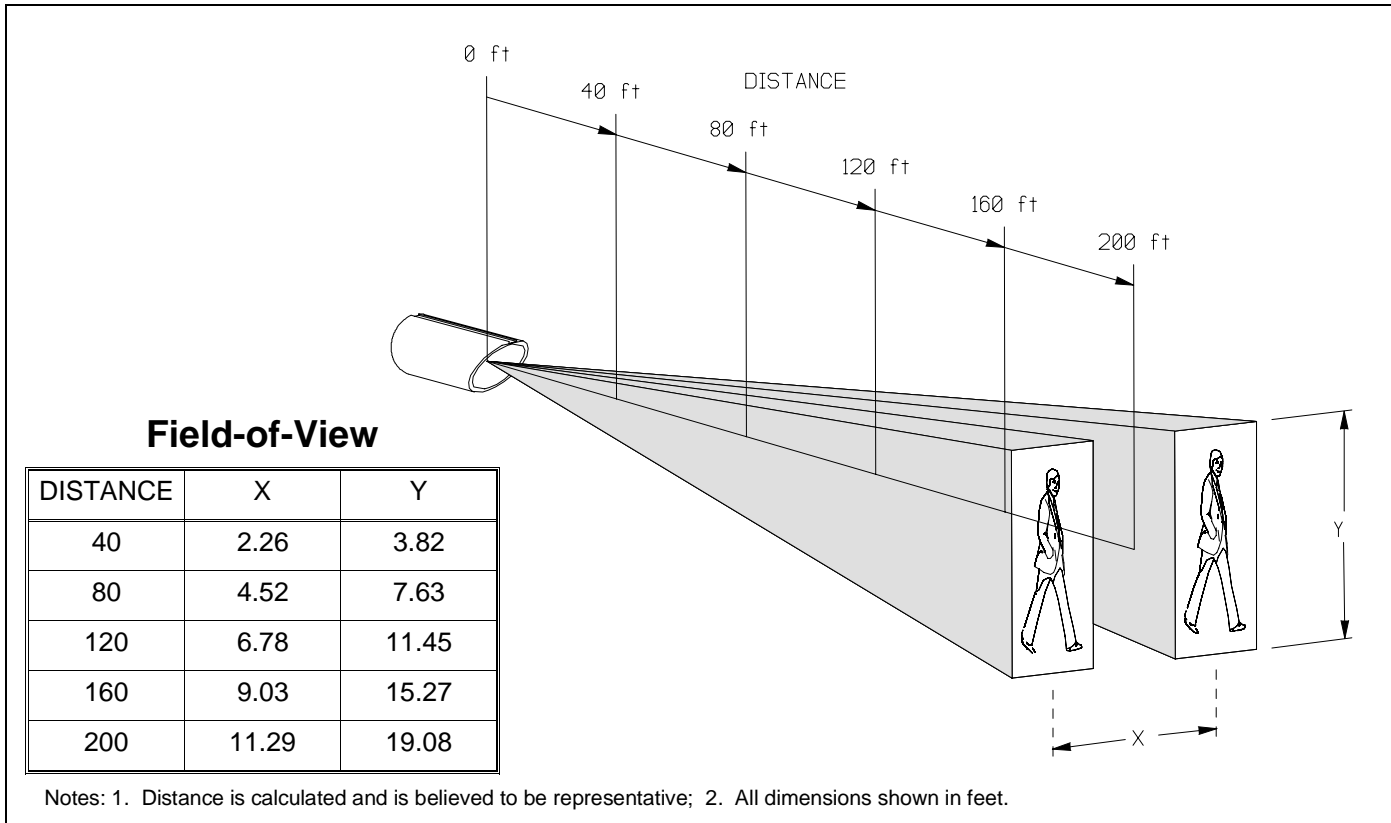


**Figure 1.2**

*Data is calculated and subject to variations in environmental changes*

are the internal tamper sense connections. The Model 8502M3 and 8502M9 tamper sense connects to V+ through a 2 megohm resistor. The Model 8502M7 tamper sense is connected to ground.

The field of view consists of two distinct segments. The area covered as a function of distance is shown in Figs 1.1, 1.2 and 1.3. This standard field of view is ideally suited for observation of a defined spot from a distance.



**Figure 1.3**

*Data is calculated and subject to variations in environmental changes*

## 1.6 DIRECTIONAL CONSIDERATIONS

When a target is traveling from the left to the right (when viewed from the rear of the telescope), Output Pin A will exhibit a signal first then Output Pin C will exhibit a signal. When a target is traveling from the right to the left (when viewed from the rear of the telescope), Output Pin C will exhibit a signal first then Output Pin A will exhibit a signal.

## 1.7 DETECTABILITY CONSIDERATIONS

These passive infrared telescopes produce an analog signal when seeing a change of optical radiation corresponding to a movement within or across the field of view. Although the telescopes are most sensitive to movements across the field of view, movement towards the telescope will also be detected with a high degree of probability.

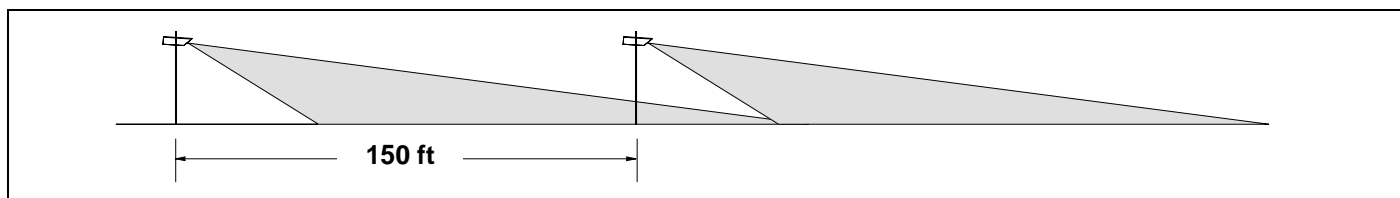
## 1.8 ENVIRONMENTAL CONSIDERATIONS

One of the major concerns is the influence of various weather conditions on the detection range. Calculations verified by actual tests show that the infrared signal attenuation can almost be neglected for points 1 to 9 on the International Visibility Scale (see Table 1) corresponding to dense fog and perfectly pure air, respectively. Only for visibility 0 (very dense fog) will the attenuation be significant, but detection range will still be typically up to 50% more than the distance the human eye will see.

## 1.9 INSTALLATION CONSIDERATIONS

These telescopes are most frequently used when the intruder's direction is important or critical. They may be used across a natural "trap" zone like a gully, river ford, or trail and for perimeter protection. They are often used across a road to signal that a vehicle has passed and in what direction. They are frequently aimed across runways of isolated or covert airstrips.

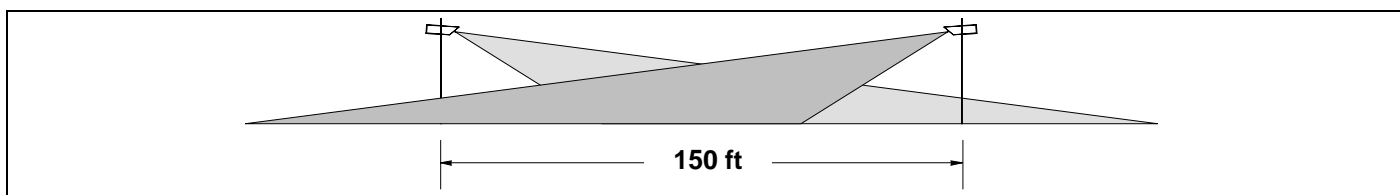
In perimeter protection applications, or similar fixed installations for people detection, it is recommended to limit the required detection range to ~150 ft by grounding out the telescope. Longer sections of a perimeter can be divided into portions of ~150 ft, each being covered by one telescope (see Fig 1.4). This kind of set-up will give reliable detection under virtually all climatic conditions.



*Figure 1.4*

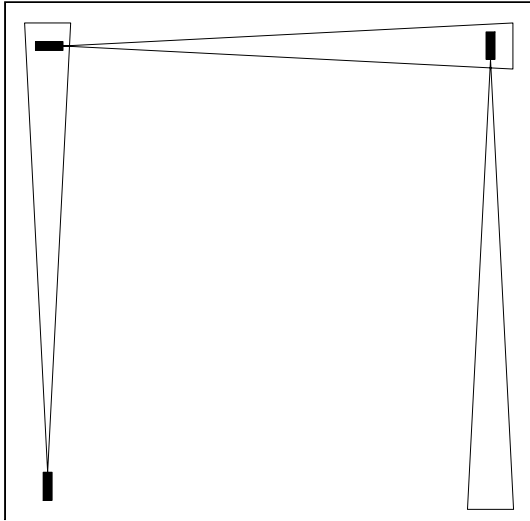
It is important to note that the range of the telescope is not limited by, but a function of, size and temperature of the target. A car or an airplane may trigger an alarm when crossing the field of view at a much longer distance depending on the conditions. This is avoided in practice by pointing the telescopes slightly downward or by having the telescopes face a defined background (wall, hill, or embankment).

An alternate, which is commonly chosen in high security applications, is to protect a given section by two telescopes facing each other (see Fig 1.5). By electrically linking two units in an "and" function, an alarm will only be triggered if both telescopes give a simultaneous alarm, indicating movement seen by both units. Naturally this type of set-up greatly reduces the false alarm probability. Additionally, such an arrangement, if switched to an "or" function at certain times of increased risk of intrusion or very poor visibility, can be made extremely sensitive.

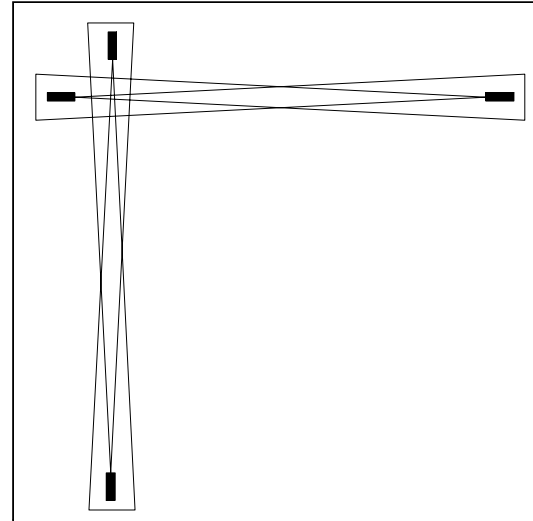


*Figure 1.5*

For protection of a corner, the following installations are recommended (Figs 1.6 & 1.7)



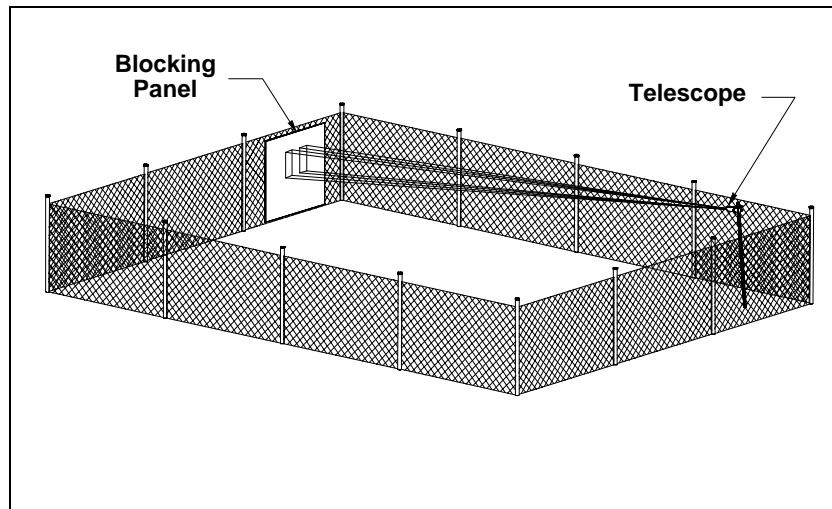
*Figure 1.6*



*Figure 1.7*

### **For Perimeter with Chain-Link Fence:**

If the telescope is aimed at the fence, it will "see through" the fence and alarm in response to people and vehicles on the other side. To avoid this, the telescopes can be aimed at the ground. Or a panel can be added to the fence. Possible materials: marine plywood or acrylic plastic sheet (this is opaque in the long wave infrared). See Fig 1.8.



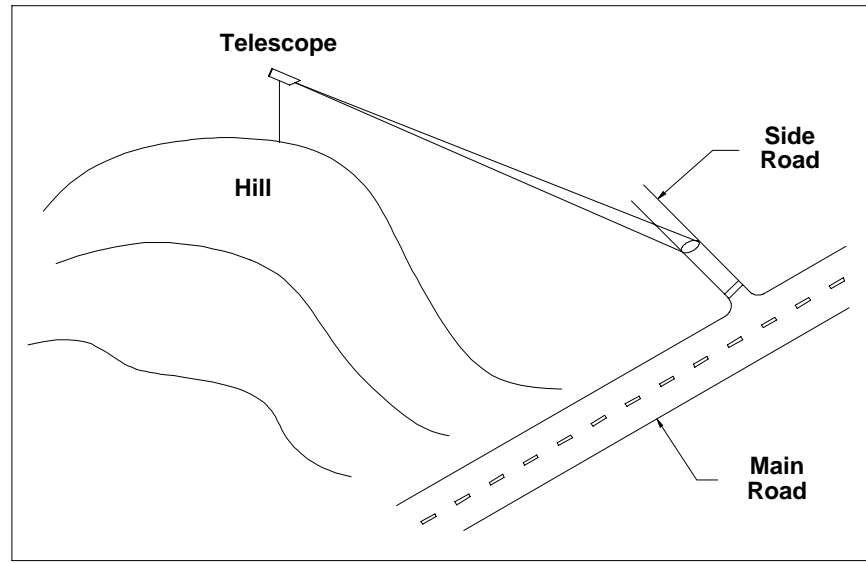
*Figure 1.8 - Use of a Blocking Panel*

## **1.10 POTENTIAL FALSE ALARM SOURCES**

Various sources may affect the performance of an outdoor security system. For instance, DO NOT aim the telescope into the horizon (straight out), UNLESS you are aiming into a wall, the side of a building or an embankment that is within your monitored perimeter. Although the telescope will detect a person at ~200 feet under most conditions, it may detect a larger heat source, like a truck or an airplane, to a distance much greater or thermal perturbations in distant atmospheric masses. Thus,



the end of the field of view should be a stable thermal background (something that changes temperature very slowly, like the earth or a concrete wall, etc.). See Fig 1.9. If the telescope seems to be giving false trips, the first thing to check (after verifying that there is proper voltages to electronics and telescope) is the aiming, to make sure that detection of motion of distant objects is not the source of unwanted alarm signals. REFER TO OPERATION, AND ALIGNMENT SECTIONS. Passive infrared detection can perform exceptionally well under almost all conditions.



**Figure 1.9 - Grounding with Actual Terrain**

## SECTION 2 - - - INSTALLATION AND OPERATION

### 2.1 INTRODUCTION AND PRECAUTIONS

Before installing the telescope, please read this section carefully. Should any difficulties arise, contact your supplier or Technical Support staff at Eltec Instruments directly.

#### **IMPORTANT NOTICES FOR INSTALLATION AND SERVICE PERSONNEL:**

##### **Handle the telescope with care**

The unit is a precision instrument and will not function to its specifications if subjected to mechanical shock or undue stress.

##### **DO NOT point the unit into the sun or other intense source of infrared radiation**

The telescope contains precision optical components that focus infrared energy onto very sensitive pyroelectric components. Intense sources of infrared will destroy these components and possibly damage the optics.

##### **DO NOT touch the front lens with bare hands**

Salts and acids from the hands may damage the surface of the lens. To clean the lens, use only a soft, clean cloth. Cloth may be moistened with distilled water or alcohol in severe conditions. Clean the lens very gently, do not apply undue pressure as the lens is fragile and may be damaged or broken.

##### **Use precautions in lightning storms**

In lightning prone areas, take measures to arrest lightning discharges and electrostatic buildup.

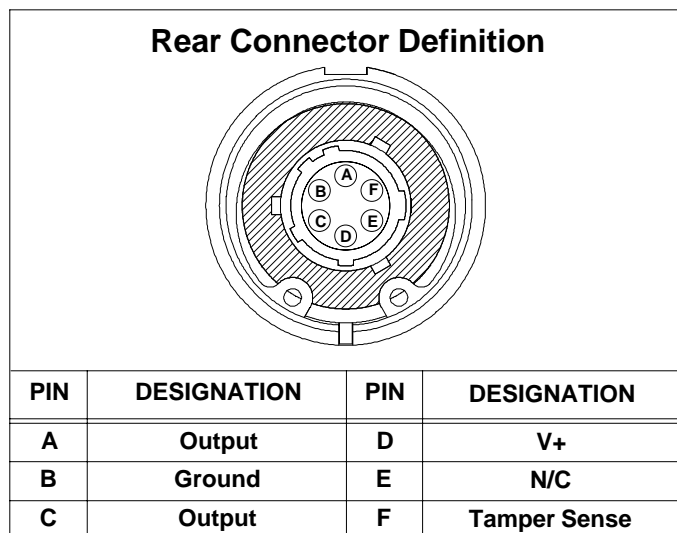
### 2.2 UNPACKING

Remove the unit from the shipping container and carefully check for signs of damage. Any such damage should be reported to your supplier or to the Technical Support staff at Eltec Instruments directly. Do not attempt to install a damaged unit until advice has been obtained.

### 2.3 POWER REQUIREMENTS

The telescope can be used over a wide voltage range from 3.0V to 15V DC. The voltage must be DC, any ripple on the supply voltage will be present at the output of the telescope. Avoid running low voltage DC next to AC power cables over long distances. Induced AC ripple and noise in the DC supply will be present at telescope's output.

### 2.4 CONNECTION TO EXTERNAL EQUIPMENT



The Model 8502M7 typically has a red retaining ring for model identification.

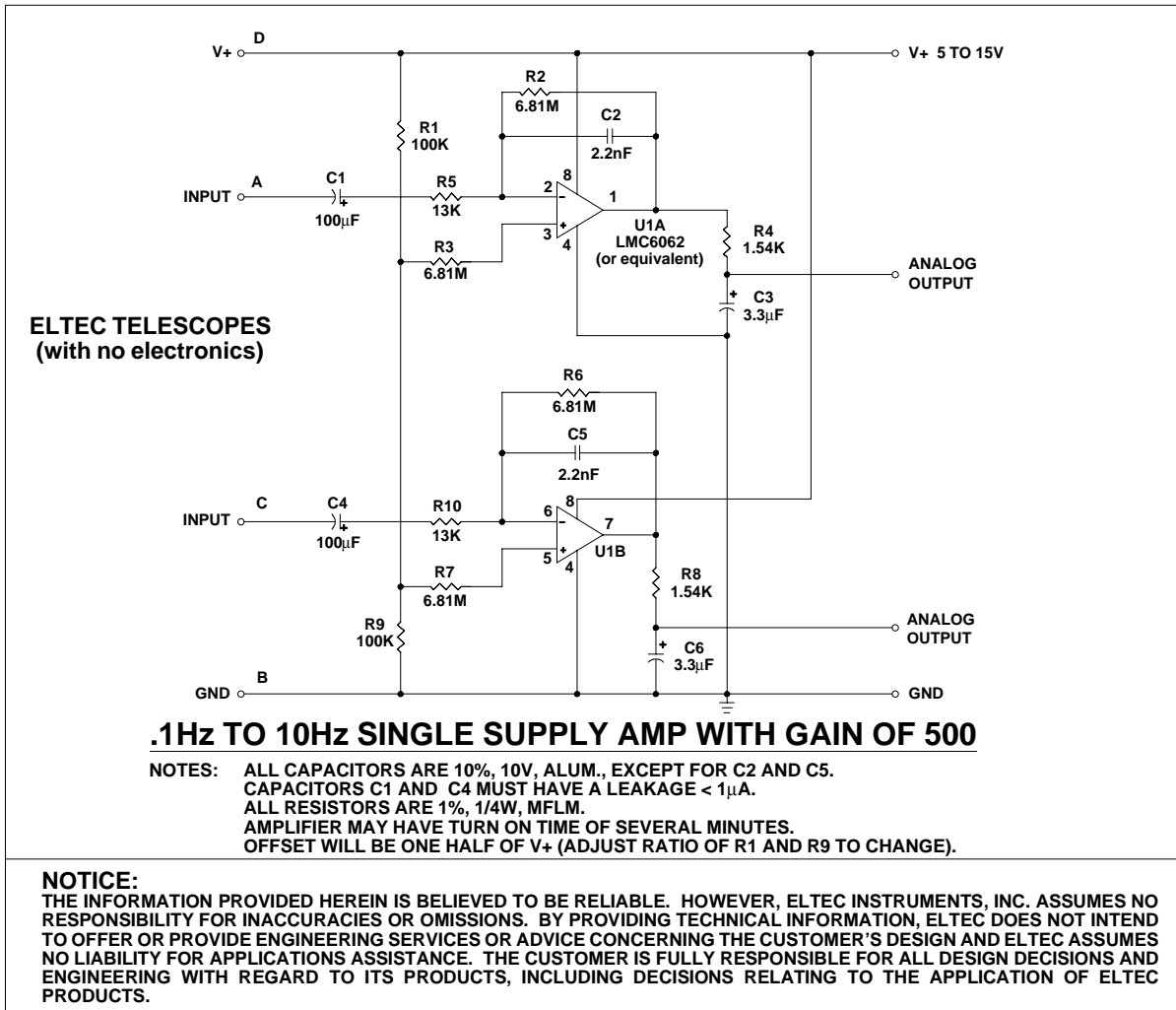
The connector (receptacle) is Bendix PT07E10-6SW or ITT-Cannon KPT07E10-6SW. Mating plugs are available in many different styles and options. Eltec recommends customers contact Bendix or ITT-Cannon directly.

### 2.5 TAMPER SENSE

The difference between the Model 8502M3/8502M9 and the Model 8502M7 are the internal tamper sense connections. The Model 8502M3 and 8502M9 tamper sense connects to V+ through a 2 megohm resistor. The Model 8502M7 tamper sense is connected to ground.

## 2.6 AMPLIFICATION REQUIREMENTS

These telescopes require customer developed signal processing. The schematic below depicts a sample amplification circuit with a single supply, 0.1Hz to 10Hz frequency response and a gain of 100, which can be tailored as needed for the individual application.



## 2.7 MECHANICAL OUTLINE

Optics and detector are sealed into a rugged watertight hermetically sealed CPVC housing providing exceptional thermal isolation and immunity to thermal shock.

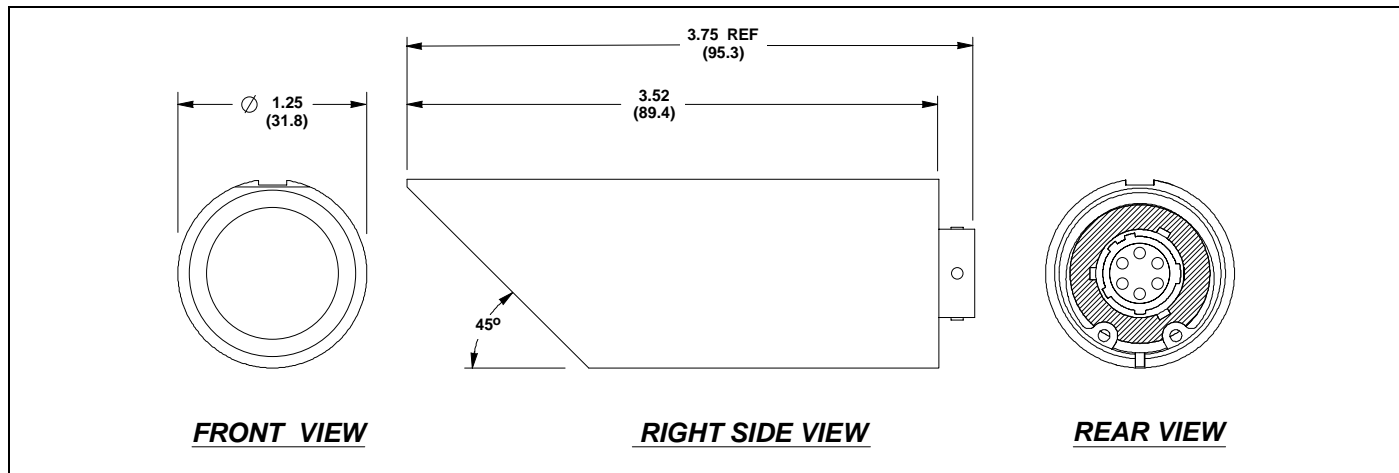


Figure 2.1

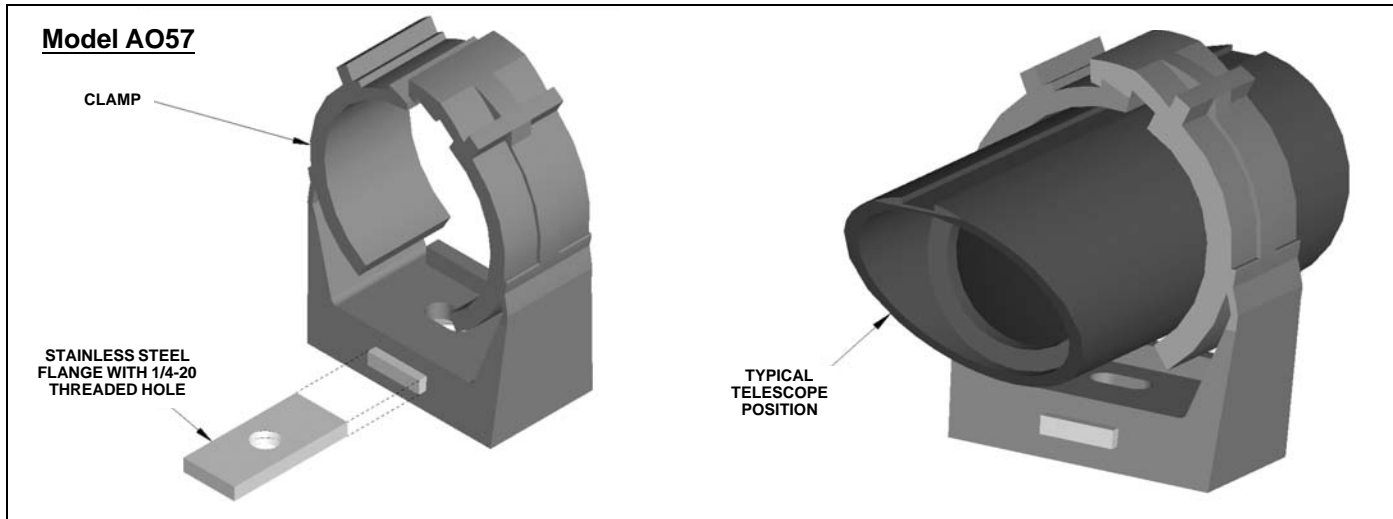
## 2.8 MOUNTING

Refer to Fig 1.2 which shows the effect of different mounting heights on coverage. A sighting groove on the top of the telescope aids in the installation process.

The telescope is an extremely sensitive detector. For this reason, mounting must be on a very stable structure. The long, narrow detection field and high sensitivity of the telescope makes it susceptible to false alarms from motion if not mounted securely.

## 2.9 MOUNTING AND ACCESSORIES

The telescopes are easily mounted on any stable vertical pole or other solid structure. For stable mounting and easy aiming the following accessories can be supplied:



## 2.10 OPERATION

### Mounting

Aim the telescope at the desired direction and then slide the telescope into the Model AO57 clamp. Squeeze the clamp at the top so that it engages and is snug around the telescope. The Model AO57 clamp flange is an internally threaded 1/4-20 hole. Note: To remove telescope from clamp, push down on telescope, then pull clamp apart at the top.

### Electrical Connections

Connect electronics to the telescope's connector, observing proper connections listed in section 2.4.

### Power-Up

When the power is applied to the telescope, there is a period of approximately 2 to 5 minutes during which the internal circuitry stabilizes. During this period, the telescope sensitivity may vary slightly as the internal temperature stabilizes. Allow 5 minutes for complete stabilization.

### Nuisance Alarms

When the telescope registers what seems to be false alarms overnight, it is sometimes difficult to identify the source of the problem. Often it is small animal activity which may be confined to only one section of a perimeter. Sometimes it is branches or other vegetation being moved by the wind into the telescope's field of view. A good approach is to "blind" the telescope with an opaque bag - - testing that it is indeed rendered insensitive to motion. Then if the unit alarms in the trouble period, the source may be the power supplied to the telescope (an unlikely problem if other telescopes run from the same supply), a fault with the telescope itself or a fault with the associated electronics. If the telescope does not alarm through the trouble period when blinded, then the actual field of view should be verified by walk testing to insure that the telescope is not picking up distant vehicles or motion from an adjacent area. In addition, many telescope users have used the scope output to trigger a recording CCTV system with time/date stamp for alarm source verification. This approach is highly recommended.

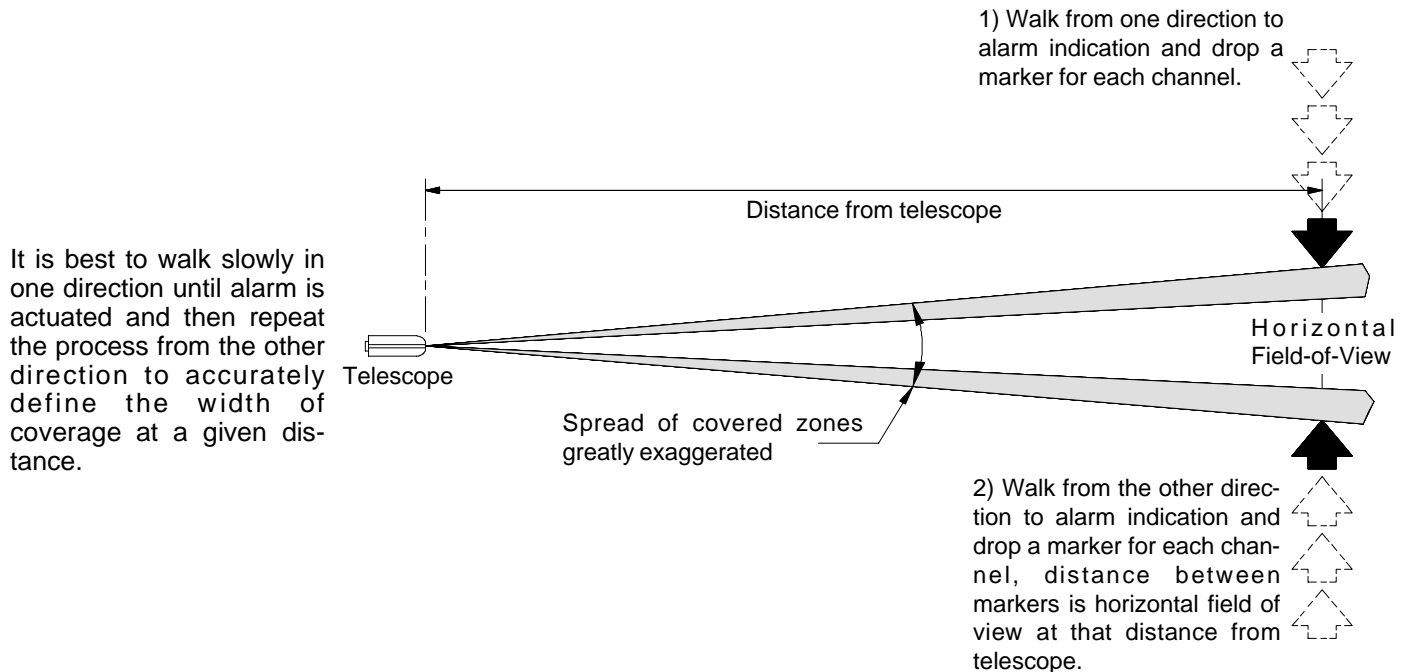
## 2.11 ALIGNMENT

To align the telescope for small installations, walk testing is recommended. This is the best way to make final adjustments to the detection area.

## 2.12 WALK TESTING

Final aiming is done by walking across the field of view and observing the point where an alarm is triggered.

## 2.13 WALK TESTING HORIZONTAL FIELD-OF-VIEW



## 2.14 MAINTENANCE

### Servicing

The telescopes are sealed units. The only servicing required is to clean the front lens every 90 days with a clean, soft cloth. This may need to be done more often in dusty environments. Cloth may be moistened with distilled water in severe conditions. Clean the lens very gently, do not apply undue pressure as the lens is fragile and may be damaged or broken. At the same time, the detection field should be walk tested to check its sensitivity. Should problems arise, please contact our Technical Support staff for advice.

**DO NOT TOUCH THE LENS WITH BARE HANDS. SALTS AND ACIDS FROM THE HANDS MAY DAMAGE THE SURFACE OF THE LENS.**

**THE TELESCOPE CONTAINS NO USER SERVICEABLE PARTS AND IN THE EVENT OF FAILURE SHOULD BE RETURNED TO ELTEC INSTRUMENTS, INC. FOR REPAIR. THE TELESCOPE IS HERMETICALLY SEALED AND NITROGEN BACKFILLED. ANY DISASSEMBLY WILL COMPROMISE THE SEAL AND VOID THE WARRANTY.**

## 2.15 MODEL 8502M3 / 8502M7 / 8502M9 SPECIFICATIONS

### Mechanical

Weight	2.3 oz (65 g)
Enclosure	Painted CPVC, hermetically sealed
Color	O.D. Green (other colors available as special order)

### Optical

Nominal Range	195 ft (60 m) with appropriate customer-supplied electronics
Optics	Refractive, Plano-Convex
Detector	Two channel Lithium Tantalate Pyroelectric

### Electrical

Supply Voltage	3 to 15 VDC
Supply Current	25 $\mu$ A max
Output	Analog

### Environmental

Operating Temperature Range	-40°C to +65°C
Storage Temperature Range	-40°C to +65°C
Sealing	Waterproof to a depth of 1 meter

**Note: Housing is hermetically sealed and nitrogen backfilled to prevent condensation of moisture on the optics at low temperatures. Any disassembly of this unit will break the seal and void the warranty.**

## 2.16 ACCESSORIES

**AO57 = Mounting Clamp**

**NOTICE:** The information provided herein is believed to be reliable. However, ELTEC Instruments, Inc. assumes no responsibility for inaccuracies or omissions. Due to industry components being incorporated into ELTEC's devices and ELTEC continually striving for product improvement, specifications may change without notice.



**ELTEC Instruments, Inc. P.O. Box 9610 Daytona Beach, Florida 32120-9610 U.S.A.**  
**Tel (USA and Canada): (800) 874-7780 Tel (Outside USA): (386) 252-0411 Fax: (386) 258-3791**  
**Web: [www.eltecinstruments.com](http://www.eltecinstruments.com) E-Mail: [Sales@eltecinstruments.com](mailto:Sales@eltecinstruments.com)**

©ELTEC INSTRUMENTS, INC. 03/2017 Printed in U.S.A. Form DS8502M3-7-9 (E-03/2017)

<b>International Visibility Scale</b>				
<b>Points</b>	<b>Qualitative Visibility</b>	<b>Range of Visibility</b>	<b>Transmissivity per Kilometer</b>	<b>Atmospheric Conditions</b>
0	Very Poor	0 - 50 m	$< 10^{-6}$	Very dense fog
1		50 - 200 m	$10^{-4} - 10^{-6}$	Dense fog; very heavy snow
2		200 - 500 m	$10^{-3} - 10^{-4}$	Moderate fog; heavy snow
3	Poor	500 - 1,000 m	$10^{-2} - 10^{-3}$	Light fog; moderate snow; thick haze
4		1 - 2 km	0.02 - 0.15	Moderate snow; very heavy rain; moderate haze
5	Intermediate	2 - 4 km	0.15 - 0.4	Light snow; heavy rain; thin haze
6		4 - 10 km	0.4 - 0.7	Moderate rain; very light snow; thin haze
7	Good	10 - 20 km	0.7 - 0.8	Light rain; no precipitation
8	Very Good	20 - 50 km	0.8 - 0.9	No precipitation
9	Exceptional	> 50 km	0.9 - 1.0	Perfectly pure air

Notes: 1. The transmittance refers to  $\lambda = 0.61 \mu$ . 2. The values for 0 - 3 points are rough estimates due to meager experimental data.  
(Bramson: Infrared Radiation, Plenum Press, N.Y., 1968)

**TABLE 1**



**ELTEC Instruments, Inc. P.O. Box 9610 Daytona Beach, Florida 32120-9610 U.S.A.**  
**Tel (USA & Canada): (800) 874-7780 Tel (Outside USA): (386) 252-0411 Fax (386) 258-3791**  
**Web: [www.eltecinstruments.com](http://www.eltecinstruments.com) E-Mail: [Sales@eltecinstruments.com](mailto:Sales@eltecinstruments.com)**